

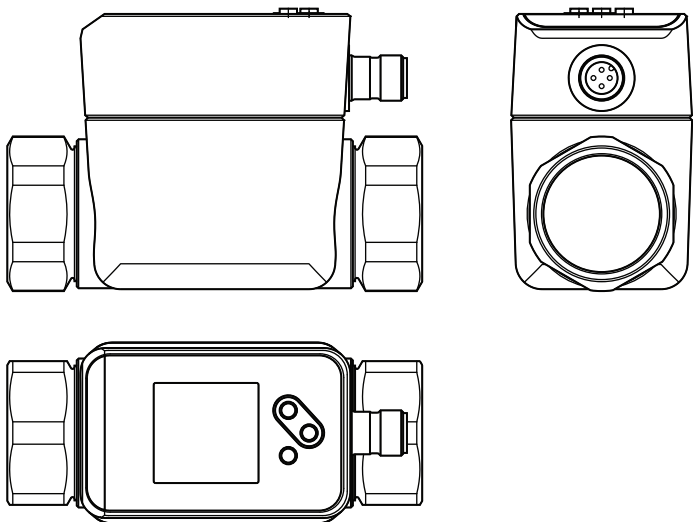

MAGX Series
Magnetic-Inductive Flow Meters
Operating Instructions



MAGX-009.2-N-050-D
MAGX-019.8-N-075-D
MAGX-039.6-N-100-D

Contents

1	Preliminary note	4
1.1	Symbols used	5
1.2	Warnings used	5
2	Safety instructions	5
3	Getting started	6
3.1	Device functions with factory setting	6
3.2	Setting options	7
4	Functions and features	7
4.1	Pressure Equipment Directive (PED)	7
4.2	Applications	7
5	Function	8
5.1	Process measured signals	8
5.2	Volumetric flow direction	9
5.2.1	Determining the volumetric flow direction [Fdir]	9
5.2.2	Detection of the volumetric flow direction [dir.F]	9
5.3	Consumed quantity monitoring	10
5.3.1	Metering method of the quantity meters	11
5.3.2	Meter reset	13
5.3.3	Consumed quantity monitoring via pulse signals	13
5.3.4	Consumed quantity monitoring via switching signal (preset counter)	14
5.4	Frequency output	15
5.5	Analogue output	17
5.6	Switching output	19
5.7	Measured value damping	20
5.8	Low flow cut-off	20
5.9	Start-up delay	20
5.10	Simulation	23
5.11	Colour of the characters in the display	24
5.12	IO-Link	25
5.12.1	Additional functions via IO-Link	25
6	Installation	26
6.1	Recommended installation position	27
6.2	Non-recommended installation position	27

6.3	Ground.....	28
6.4	Installation in pipes	29
7	Electrical connection.....	30
8	Operating and display elements	32
9	Menu.....	33
9.1	Process value display (RUN).....	33
9.2	Main menu	34
9.3	Extended functions EF	35
9.4	Submenu OUT1 and OUT2	36
9.5	Submenu CFG and TOTL.....	39
9.6	Submenu MEM and DIS.....	41
9.7	Submenu COLR and SIM.....	43
10	Set-up	45
11	Parameter setting.....	45
11.1	Parameter setting in general.....	46
11.1.1	Select submenu	46
11.1.2	Change to the process value display (RUN mode).....	46
11.1.3	Locking / unlocking	46
11.1.4	Timeout.....	47
11.2	Settings for volumetric flow monitoring	47
11.2.1	Limit monitoring OUT1 or OUT2 / hysteresis function	47
11.2.2	Limit monitoring OUT1 or OUT2 / window function	47
11.2.3	Switching signal volumetric flow direction OUT1 or OUT2	47
11.2.4	Frequency signal volumetric flow OUT1	48
11.2.5	Analogue signal volumetric flow OUT2	48
11.3	Settings for consumed quantity monitoring.....	48
11.3.1	Metering method of the totalisers	48
11.3.2	Quantity monitoring via pulse output OUT1	48
11.3.3	Quantity monitoring via the preset counter OUT1	49
11.3.4	Manual meter reset.....	49
11.3.5	Time-controlled meter reset	49
11.3.6	Deactivate meter reset.....	49
11.3.7	Meter reset via external signal.....	49
11.3.8	Read consumption values	50
11.4	Settings for temperature monitoring.....	50

11.4.1	Limit monitoring OUT1 or OUT2 / hysteresis function	50
11.4.2	Limit monitoring OUT1 or OUT2 / window function	50
11.4.3	Frequency signal temperature OUT1	50
11.4.4	Analogue signal temperature OUT2	51
11.5	User settings (optional).....	51
11.5.1	Menu language	51
11.5.2	Standard display	51
11.5.3	Standard unit of measurement for volumetric flow	52
11.5.4	Standard unit of measurement for temperature	52
11.5.5	Measured value damping	52
11.5.6	Start-up delay	52
11.5.7	Output logic.....	52
11.5.8	Low flow cut-off	52
11.5.9	Volumetric flow direction	52
11.5.10	Colour of the characters in the display	53
11.5.11	Error behaviour of the outputs.....	54
11.5.12	Restore factory setting.....	54
11.6	Diagnostic functions.....	55
11.6.1	Read min/max values	55
11.6.2	Simulation	55
12	Operation.....	55
13	Troubleshooting	56
14	Maintenance, repair and disposal.....	58
15	Factory setting	59

1 Preliminary note



You will find detailed instructions, technical data, approvals and further information using the QR code on the unit / packaging or at www.ifm.com.

1.1 Symbols used

- ▶ Instruction
- > Reaction, result
- [...] Designation of keys, buttons or indications
- Cross-reference



Important note

Non-compliance may result in malfunction or interference.



Information

Supplementary note.

UK

1.2 Warnings used



CAUTION

Warning of personal injury.

Slight reversible injuries may result.

2 Safety instructions

- The device described is a subcomponent for integration into a system.
 - The manufacturer is responsible for the safety of the system.
 - The system manufacturer undertakes to perform a risk assessment and to create a documentation in accordance with legal and normative requirements to be provided to the operator and user of the system. This documentation must contain all necessary information and safety instructions for the operator, the user and, if applicable, for any service personnel authorised by the manufacturer of the system.
- Read this document before setting up the product and keep it during the entire service life.
- The product must be suitable for the corresponding applications and environmental conditions without any restrictions.
- Only use the product for its intended purpose (→ Functions and features).
- Only use the product for permissible media (→ Technical data).
- If the operating instructions or the technical data are not adhered to, personal injury and/or damage to property may occur.

- The manufacturer assumes no liability or warranty for any consequences caused by tampering with the product or incorrect use by the operator.
- Installation, electrical connection, set-up, operation and maintenance of the product must be carried out by qualified personnel authorised by the machine operator.
- Protect units and cables against damage.

3 Getting started

When the unit is used with factory setting the volumetric flow is monitored by providing a switching signal and an analogue signal.

The process values for volumetric flow and temperature and the meter readings (current and saved values) as well as error messages can be read from the display.

All process values and messages are available via the IO-Link interface irrespective of the output configuration.

A simulation model allows simplified set-up of the sensor.

3.1 Device functions with factory setting

Output OUT1:

- Switching signal for volumetric flow (hysteresis function normally open, PnP, SP1 and rP1 → 15)
- Measured value damping 0.6 seconds, no start-up delay and minimal low flow cut-off
- In case of a fault the output switches OFF

Output OUT2:

- Analogue signal for volumetric flow (measuring range unscaled)
- In case of a fault the analogue signal goes to 3.5 mA

Display:

- Text in English, colour of the characters black/white
- Simultaneous display of current process values for volumetric flow and temperature and quantity meter
- Low refresh rate, 75 % display brightness

3.2 Setting options

- Output functions of OUT1 and OUT2 (temperature or volumetric flow; switching, pulse, frequency, analogue signal, totaliser function)
- Reversal of the volumetric flow direction, monitoring of the volumetric flow
- Response times for volumetric flow measurement (measured value damping, start-up delay, low flow cut-off)
- Error behaviour of the outputs
- Standard views of the display (unit of measurement, process values, quantity meter, refresh rate, rotation, brightness, process value-dependent change of the colour of the characters)

4 Functions and features

The unit monitors liquid media. It detects flow velocity, volume flow (volumetric flow quantity/time), consumed quantity and medium temperature.

4.1 Pressure Equipment Directive (PED)

The units comply with the Pressure Equipment Directive and are designed and manufactured for group 2 fluids according to the sound engineering practice. Use of group 1 fluids on request.

4.2 Applications

Conductive liquids with the following properties:

- Conductivity: $\geq 20 \mu\text{S/cm}$
- Viscosity: $< 70 \text{ mm}^2/\text{s}$ at $40 \text{ }^\circ\text{C}$; $< 70 \text{ cSt}$ at $104 \text{ }^\circ\text{F}$



This is a class A product. This product may cause radio interference in domestic areas.

- ▶ If required, take appropriate EMC screening measures.

5 Function

- The unit detects the volumetric flow on the magnetic-inductive volumetric flow measuring principle.
- As additional process value the unit detects the medium temperature with volumetric flow.
- The unit has an IO-Link interface.
- The unit displays the current process values.
- The unit has many self-diagnostic options.
- A simulation mode allows simplified set-up of the sensor.

5.1 Process measured signals

The unit generates 2 output signals according to the parameter setting:

OUT1: 9 selection options

- Switching signal for volumetric flow
- Switching signal for temperature
- Switching signal for volumetric flow direction
- Switching signal for preset counter
- Pulse signal for quantity meter
- Frequency signal for volumetric flow
- Frequency signal for temperature
- IO-Link
- OFF (output switched to high impedance)

OUT2: 7 selection options

- Switching signal for volumetric flow
- Switching signal for temperature
- Switching signal for volumetric flow direction
- Analogue signal for volumetric flow
- Analogue signal for temperature
- Input for external meter reset signal (InD)
- OFF (output switched to high impedance)

5.2 Volumetric flow direction

In addition to the flow velocity and the volumetric flow, the unit also detects the volumetric flow direction.

5.2.1 Determining the volumetric flow direction [Fdir]

An arrow with the text "flow direction" on the unit indicates the positive flow direction. The volumetric flow direction can be reversed (→ 11.5.9).



- ▶ Use the supplied label to mark the changed volumetric flow direction (new positive flow direction).

Volumetric flow...	Process value display
corresponds to the marked volumetric flow direction	+ (positive)
against the marked volumetric flow direction	- (negative)

UK

5.2.2 Detection of the volumetric flow direction [dir.F]

When [dir.F] is activated (→ 11.2.5), the volumetric flow direction is indicated by a switching signal.

The output is switched on until the volumetric flow falls below the set minimum volumetric flow quantity in negative flow direction (-LFC)(1).

Then the following applies:

- The output switches ON when volumetric flow is above +LFC (2).
- The output switches OFF when volumetric flow is below -LFC (3).

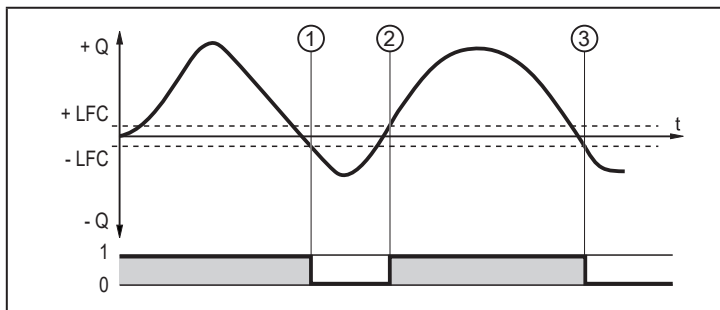

Fig. 1: Monitoring of the volumetric flow direction by switching signals

+ Q : Volumetric flow in positive flow direction

- Q : Volumetric flow in negative flow direction
- + LFC: Minimum volumetric flow (low flow cut-off) in positive flow direction
- LFC : Minimum volumetric flow (low flow cut-off) in negative flow direction

LFC → 5.8 Low flow cut-off



Positive volumetric flow direction = marked flow direction, with factory setting marked by the arrow on the unit or after change via [Fdir] marked by the supplied label (→ 5.2.1).

5.3 Consumed quantity monitoring

The unit has three internal quantity meters (= totalisers). The totalisers continuously sum up the consumed quantity and provide three process values via the parameters [Vol.1], [Vol.2] and [Vol.L]:

Totaliser	Process value	Read access via IO-Link
Vol.1	totaliser 1	cyclical
Vol.2	totaliser 2	acyclical
Vol.L	lifetime totalisator (= meter reading over the whole lifetime)	acyclical



The totalisers only sum up volumetric flow quantities above the LFC value → 5.8 Low flow cut-off.



The metering method of the totalisers Vol.1 and Vol.2 can be set so that volumetric flow values are either ignored, subtracted or totalled in negative volumetric flow direction (→ 5.3.1).



The metering method of Vol.L cannot be set. It totals all volumetric flow quantities irrespective of the volumetric flow direction.

The process values of the quantity meter (totaliser) can be displayed (→ 11.3.8) or read via the IO-Link interface.

Pulse signals (pulse output) or a switching signal (preset counter) can be used to monitor the consumed quantity.

→ 5.3.3 Consumed quantity monitoring via pulse signals

→ 5.3.4 Consumed quantity monitoring via switching signal (preset counter)

5.3.1 Metering method of the quantity meters

The quantity meters take account of the volumetric flow direction when totalling the consumed quantity (→ Fig. 2). The following metering methods can be defined via the parameters [FPro1] and [FPro2]:

[FPro1] [FPro2]*	Metering method
0+	Negative volumetric flow quantity values (against the marked flow direction) are not taken into account for totalling.
- +	Negative volumetric flow quantity values are subtracted from the consumed quantity.
++	All volumetric flow quantity values are totalled irrespective of the volumetric flow direction.

* [FPro1] = metering method for totaliser Vol.1

[FPro2] = metering method for totaliser Vol.2

UK

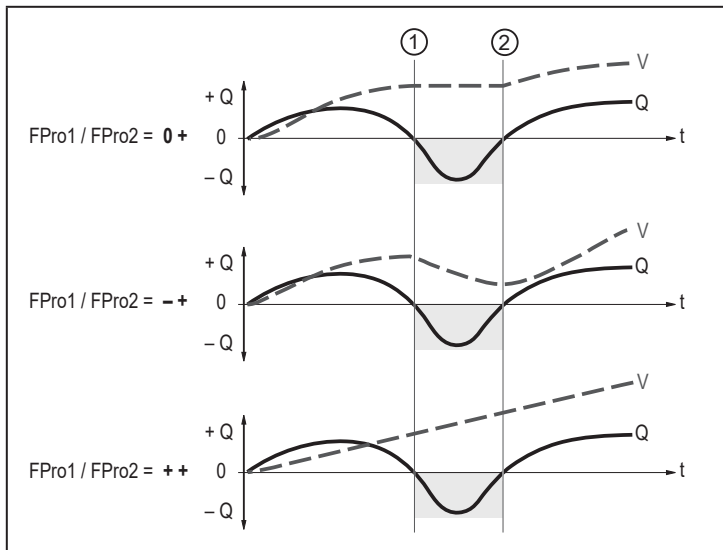

Fig. 2: Taking account of the volumetric flow direction when totalling the consumed quantity

+ Q = volumetric flow quantity in positive direction

- Q = volumetric flow quantity in negative direction

V = volumetric flow quantity absolute (= sum of negative and positive volumetric flow)

① Volumetric flow changes to negative direction

② Volumetric flow changes to positive direction

When the volumetric flow direction is changed a minimum volumetric flow quantity is taken into account: - LFC in negative direction; + LFC in positive direction (→ 5.2.2).

5.3.2 Meter reset

There are different ways to reset the quantity meters.

- 11.3.4 Manual meter reset
- 11.3.5 Time-controlled meter reset
- 11.3.7 Meter reset via external signal
- Meter reset via the IO-Link interface

If the quantity meter is not reset by applying one of the above-mentioned methods, an automatic reset is made when the maximum volumetric flow quantity that can be displayed is exceeded (overflow).

UK



The total meter reading [Vol.L] cannot be reset.



The meter saves the totalled volumetric flow quantity every few seconds. After a power failure this value is available as the current meter reading. If a time-controlled reset is set, the elapsed time of the set reset interval is also saved. This means that the possible data loss can amount to a maximum of a few seconds.

5.3.3 Consumed quantity monitoring via pulse signals

Every time the volumetric flow quantity (pulse value) set under [ImPS] has been reached, the output provides a pulse signal. The pulse signal consists of a short switching on and off of the output. The switching status LEDs on the unit do not display the switching operation.



Pulse signals are not available via the IO-Link interface.

5.3.4 Consumed quantity monitoring via switching signal (preset counter)

When the volumetric flow quantity set under [ImPS] has been reached, the output provides a switching signal. The output remains switched until the meter reset. After a totaliser reset metering starts again.



The accuracy of the consumed quantity measurement depends on the accuracy of the volumetric flow measurement.

By setting [rTo1] it is set when the output switches and when the totaliser Vol.1 is reset:

[rTo1]	Output	Meter reset
OFF	<ul style="list-style-type: none">• The output switches when the volumetric flow quantity set under [ImPS] is reached.• The output remains switched until the meter reset.	<ul style="list-style-type: none">• The preset counter is reset<ul style="list-style-type: none">- when a manual reset is made (→ 11.3.4) or- when the maximum display range is exceeded (overflow).
1, 2,... h 1, 2,... d 1, 2,... w	<ul style="list-style-type: none">• The output switches only when the volumetric flow quantity set under [ImPS] is reached within the set time.• The output remains switched until the meter reset.	<ul style="list-style-type: none">• If the output is not switched the preset counter is reset when the set time is exceeded.• If the output is switched, the preset counter is only reset<ul style="list-style-type: none">- when a manual reset is made (→ 11.3.4) or- when the maximum display range is exceeded (overflow).

By setting [rTo2] it is set when the totaliser Vol. 2 is reset. The setting of [rTo2] has no effect on the output:

[rTo2]	Output	Meter reset
OFF	No effect on the output	<ul style="list-style-type: none">• The preset counter is reset<ul style="list-style-type: none">- when a manual reset is made (→ 11.3.4) or- when the maximum display range is exceeded (overflow).

[rTo2]	Output	Meter reset
[rTo2] = 1, 2,... h 1, 2,... d 1, 2,... w	No effect on the output	<ul style="list-style-type: none"> The preset counter is reset <ul style="list-style-type: none"> when a manual reset is made (→ 11.3.4) or when the maximum display range is exceeded (overflow) or when the set time is exceeded.

5.4 Frequency output

The unit provides a frequency signal that is proportional to the volumetric flow (velocity or volume flow) or to the medium temperature.

Within the measuring range the frequency signal is between 0 and 10 kHz.

The frequency signal is scalable:

- [FrP1] defines the frequency signal in Hz that is provided when the upper measured value (MEW or FEP1) is reached.

The measuring range is scalable:

- [FSP1] defines the lower measured value from which a frequency signal is provided.
Note: [FSP1] cannot be set for volumetric flow measurement.
- [FEP1] defines the upper measured value at which the frequency signal FrP1 is provided.



Minimum difference between [FSP1] and [FEP1]
= 20 % of the final value of the measuring range.

If the measured value is outside the measuring range or in the event of an internal error, the frequency signals indicated in figure 3 are provided.

For measured values outside the display range or in case of an error, messages are displayed (OL, cr.OL, Err; →).

The frequency signal in case of an error is adjustable (→ 11.5.11):

- [FOU] = On defines that the frequency signal goes to the upper final value (130 % FrP1) in case of an error.
- [FOU] = OFF defines that the frequency signal is 0 Hz in case of an error.
- [FOU] = OU defines that in case of an error the frequency signal reacts as defined by the current parameters.



Frequency signals are not available via the IO-Link interface.

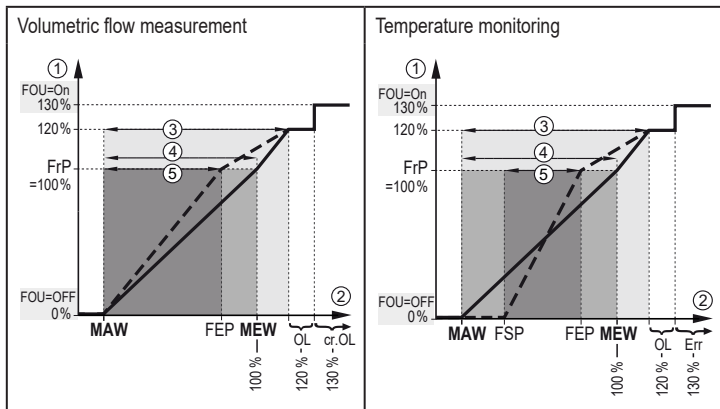

Fig. 3: Output characteristics frequency output

- ① Frequency signal in kHz
- ② Measured value (volumetric flow or temperature)
- ③ Display range
- ④ Measuring range
- ⑤ Scaled measuring range

MAW: Initial value of the measuring range with non-scaled measuring range (with setting of low flow cut-off for Q: signal output starting at MAW + LFC → 5.8.)

MEW: Final value of the measuring range with non-scaled measuring range

FSP: Frequency start point with scaled measuring range (only temperature)

FEP: Frequency end point with scaled measuring range

FrP: Frequency signal for upper measured value

OL: Above the display range

cr.OL: Above the detection zone (error)

Err: The unit is in the error state

5.5 Analogue output

The unit provides an analogue signal that is proportional to the volumetric flow (velocity or volume flow) or to the medium temperature.

Within the measuring range the analogue signal is between 4 and 20 mA.

The measuring range is scalable:

- [ASP2] defines at which measured value the output signal is 4 mA.
- [AEP2] defines at which measured value the output signal is 20 mA.



Minimum difference between [ASP2] and [AEP2]
= 20 % of the final value of the measuring range.

UK

If the measured value is outside the measuring range or in the event of an internal error, the current signal indicated in figure 4 is provided.

For measured values outside the display range or in case of an error, messages are displayed (cr.UL, UL, OL, cr.OL, Err; →).

The analogue signal in case of an error is adjustable (→ 11.5.11):

- [FOU] = On defines that the analogue signal goes to the upper final value (21.5 mA) in case of an error.
- [FOU] = OFF defines that the analogue signal goes to the lower final value (3.5 mA) in case of an error.
- [FOU] = OU defines that in case of an error the analogue signal reacts as defined by the current parameters.

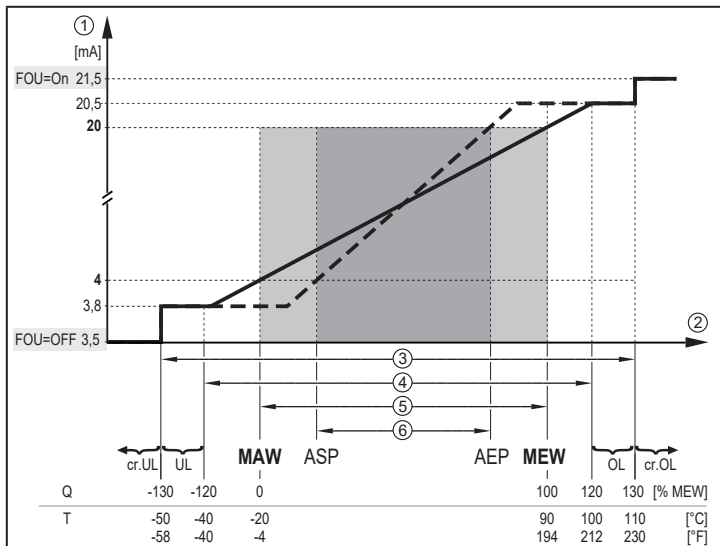

Fig. 4: Characteristics of the analogue output according to the standard IEC 60947-5-7

- ① Analogue signal
- ② Measured value (volumetric flow or temperature)
- ③ Detection zone
- ④ Display range
- ⑤ Measuring range
- ⑥ Scaled measuring range

Q: Volumetric flow (negative volumetric flow quantity value = volumetric flow against the marked flow direction).

T: Temperature

MAW: Initial value of the measuring range with non-scaled measuring range. (With setting of low flow cut-off for Q: signal output starting at MAW + LFC → 5.8.)

MEW: Final value of the measuring range with non-scaled measuring range

ASP: Analogue start point with scaled measuring range

AEP: Analogue end point with scaled measuring range

UL: Below the display range

OL: Above the display range

cr.UL: Below the detection zone (error)

cr.OL: Above the detection zone (error)

5.6 Switching output

OUTx changes its switching status if it is above or below the set switching limits (flow velocity or volume flow or temperature). Hysteresis or window function can be selected. Example of volumetric flow monitoring:

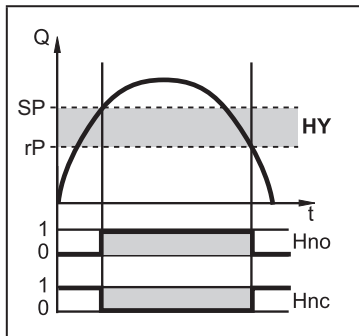

Fig. 5: hysteresis function

SP = set point

rP = reset point

HY = hysteresis

Hno / Fno = NO (normally open)

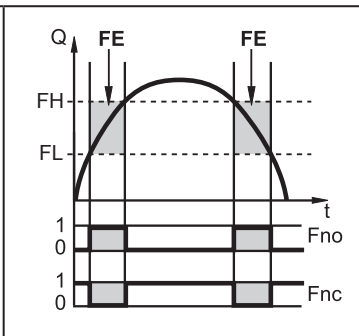

Fig. 6: window function

FH = upper limit

FL = lower limit

FE = window

Hnc / Fnc = NC (normally closed)



When the hysteresis function is set, the set point (SP) is defined first and then the reset point (rP) which must have a lower value. If only the set point is changed, the reset point is changed automatically; the difference remains constant.



When the window function is set, the upper limit (FH) and the lower limit (FL) have a fixed hysteresis of 0.25 % of the final value of the measuring range. This keeps the switching status of the output stable if the volumetric flow varies slightly.

5.7 Measured value damping

The damping time [dAP] enables setting after how many seconds the output signal has reached 63 % of the final value if the volumetric flow value changes suddenly. The set damping time stabilises the switching outputs, the analogue outputs, the display and the process value transmission via the IO-Link interface.

The damping time is added to the response time of the sensor (→ Technical data).

The signals UL, cr.UL, OL and cr.OL (→) are determined by taking the damping time into account.



The damping time only has an effect on the volumetric flow measurement.

5.8 Low flow cut-off

With the function low flow cut-off [LFC] it is possible to suppress low volumetric flow values. Volumetric flow below the LFC value is evaluated by the sensor as standstill ($Q = 0$).

5.9 Start-up delay



The start-up delay [dSt] influences the switching outputs of the volumetric flow monitoring.

If the start-up delay is active ($[dSt] > 0$), the following applies: As soon as the volumetric flow quantity exceeds the LFC value (→ 5.8), the following processes are carried out:

- > The start-up delay is activated.
- > The outputs switch as programmed: ON for NO function, OFF for NC function.

After activation of the start-up delay there are 3 options:

1. The volumetric flow increases quickly and reaches the set point / good range within [dSt].
 - > Outputs remain active.
2. The volumetric flow increases slowly and does not reach the set point / good range within [dSt].
 - > Outputs are reset.

3. Volumetric flow falls below [LFC] within [dSt].
- > Outputs are reset at once; [dSt] is stopped.

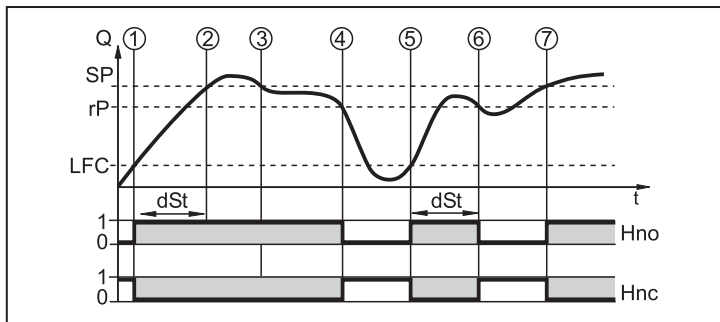

Fig. 7: dSt for hysteresis function (Example)

	Condition	Reaction
1	Volumetric flow quantity Q reaches LFC	dSt starts, output becomes active
2	dSt elapsed, Q reached SP	Output remains active
3	Q below SP but above rP	Output remains active
4	Q below rP	Output is reset
5	Q reaches again LFC	dSt starts, output becomes active
6	dSt elapsed, Q has not reached SP	Output is reset
7	Q reaches SP	Output becomes active

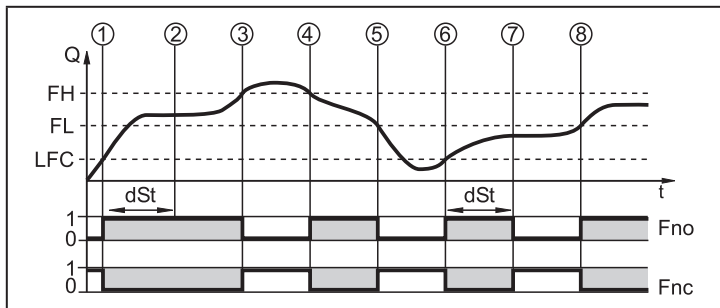

Fig. 8: dSt for window function (Example)



	Condition	Reaction
1	Volumetric flow quantity Q reaches LFC	dSt starts, output becomes active.
2	dSt elapsed, Q reached good range	Output remains active
3	Q above FH (leaves good range)	Output is reset
4	Q again below FH	Output becomes active again
5	Q below FL (leaves good range)	Output is reset again
6	Q reaches again LFC	dSt starts, output becomes active
7	dSt elapsed, Q has not reached good range	Output is reset
8	Q reaches good range	Output becomes active

5.10 Simulation

With this function, the process values volumetric flow, temperature and meter reading of the totaliser are simulated and their signal chain is checked.

When the parameters cr.UL, UL, OL und cr.OL are set, process values that lead to an error message or warning can be simulated (→).

When the simulation is started, the values of the totalisers 1-3 are frozen and the simulated totaliser is set to 0. The simulated volumetric flow value then has an effect on the simulated totaliser. When the simulation is ended, the initial totaliser values are restored.

-  The simulation has no effect on the current process values. The outputs operate as previously set.
-  During the simulation the original totaliser value remains saved without any changes even if there is a real volumetric flow.
-  During the simulation no error message of the current application is available. They are suppressed by the simulation.

5.11 Colour of the characters in the display

Via the parameters [coL.F], [coL.T] and [coL.V] the colour of the characters in the display can be set:

- Permanent definition of the display colour:
 - bk/wh (black/white)
 - yellow
 - green
 - red
- Colour change from red to green or vice versa (Fig. 9):
 - r-cF (red display colour between the limits cFL...cFH)
 - G-cF (green display colour between the limits cFL...cFH)

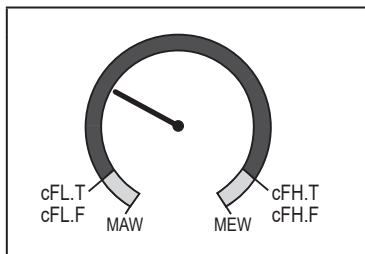

cFL.T = lower limit for temperature
cFL.F = lower limit for volumetric flow
cFH.T = upper limit for temperature
cFH.F = upper limit for volumetric flow

MAW = initial value of the measuring range
MEW = final value of the measuring range

Fig. 9: Colour setting window function



The limits can be freely selected within the measuring range and are independent of the output function set for OUT1 and OUT2.

5.12 IO-Link

This unit has an IO-Link communication interface which enables direct access to process and diagnostic data. In addition it is possible to set the parameters of the unit while it is in operation. Operation of the unit via the IO-Link interface requires an IO-Link master.

With a PC, suitable IO-Link software and an IO-Link adapter cable communication is possible while the system is not in operation.

The IODDs necessary for the configuration of the unit, detailed information about process data structure, diagnostic information, parameter addresses and the necessary information about the required IO-Link hardware and software can be found at www.ifm.com.

The IO-Link interface provides the following additional functions using suitable hardware and software:

- Remote parameter setting of the unit
- Noise-immune signal transmission without measured value losses
- Transmission of the parameter settings to a replaced unit or to other units of the same type
- Simultaneous reading of all process values (volumetric flow, temperature, totaliser), the binary switching signals and the device status
- Comprehensive display of error and event messages (events)
- Paperless logging of parameter sets, process values and diagnostic information

5.12.1 Additional functions via IO-Link

The following functions are only available via the IO-Link interface:

Function	Explanation
Flash ON / Flash OFF	Standard command for localising the sensor in the system. When activated: <ul style="list-style-type: none">> Switching status LEDs flashing.> Display: "IO-Link" (green, flashing)

Function	Explanation
Flow Override	<p>When activated: simulation volumetric flow standstill ($Q = 0$)</p> <ul style="list-style-type: none"> > All outputs behave as with volumetric flow standstill. <p> During the simulation the original totaliser value remains saved without any changes even if there is a real volumetric flow.</p>
Lock via system	<p>When activated: setting buttons locked via parameter setting software, parameter change rejected.</p>

6 Installation



CAUTION!

If the medium temperature is above 50 °C (122 °F) parts of the housing can increase in temperature to over 65 °C (149 °F).

- > Risk of burns.
- ▶ Protect the housing against contact with flammable substances and unintentional contact.
- ▶ Apply the supplied warning label to the sensor cable.



- ▶ Ensure that the system is free of pressure during installation.
- ▶ Ensure that no media can leak at the mounting location during installation.



The unit can be installed independently of the orientation if the following is ensured:

- No air bubbles can form in the pipe system.
- The pipes are always completely filled.



Calming sections on the sensor's inlet or outlet side are not necessary.

6.1 Recommended installation position

- ▶ Install the unit so that the measuring pipe is always completely filled.
- ▶ Install in front of or in a rising pipe.

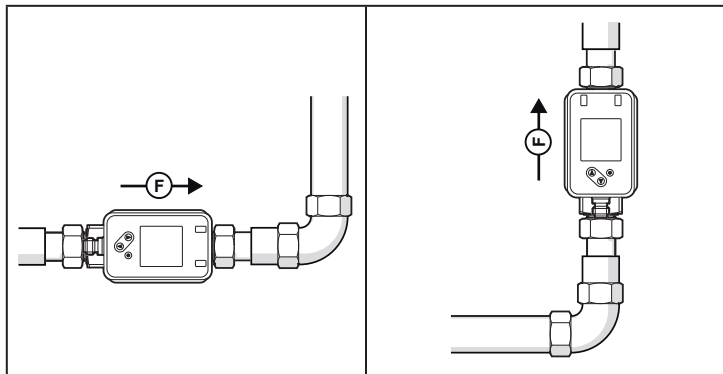

UK

6.2 Non-recommended installation position

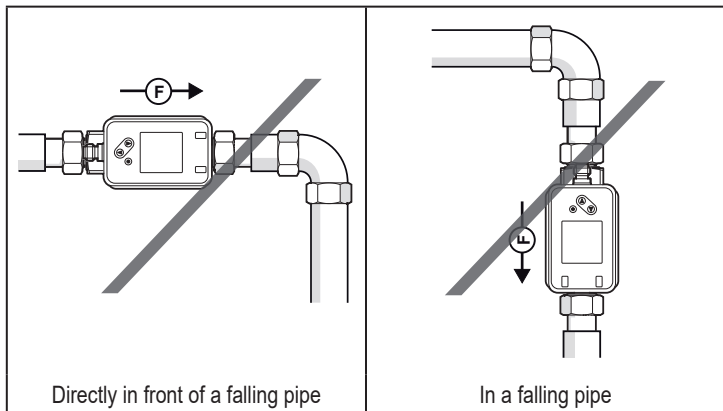

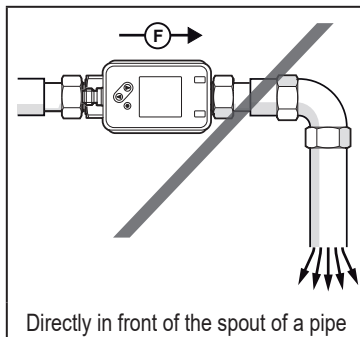

Directly in front of the spout of a pipe

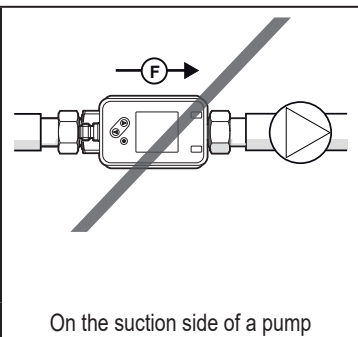

On the suction side of a pump

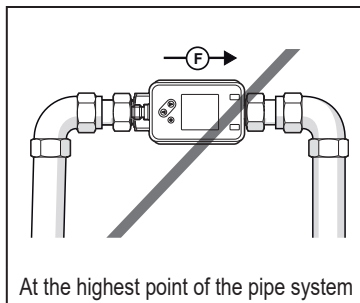

At the highest point of the pipe system

F = volumetric flow direction

6.3 Ground



If installed in an ungrounded pipe system (e.g. plastic pipes), the unit must be grounded (functional earth).

Ground brackets for the M12 connector are available as accessories

→ www.ifm.com.

6.4 Installation in pipes

The units with a G thread can be installed in the pipes using adapters.

Information about the available mounting accessories at www.ifm.com.

A correct fit of the unit and ingress resistance of the connection are only ensured using ifm adapters.

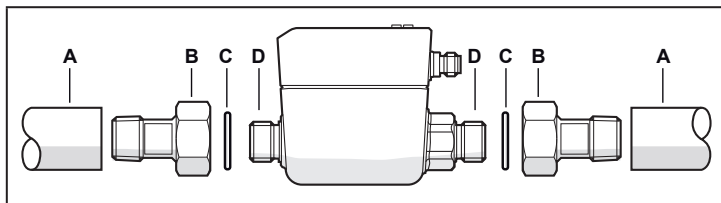

1. Grease the threads of the process connection, adapter and sensor. Use a lubricating paste which is suitable and approved for the application.
2. Screw the adapter (B) into the pipe (A).
3. Place the seals (C) and install the unit according to the marked flow direction.
4. Screw the adapter (B) with the process connections (D) until it is hand-tight.
5. Tighten the two adapters in opposite direction:
 - tightening torque DN15...DN25: 30 Nm
 - tightening torque DN6: 15 Nm

After installation air bubbles in the system can affect the measurement.

► Corrective measure: Rinse the system after installation for ventilation.

7 Electrical connection



The unit must be connected by a qualified electrician.
Voltage supply according to EN 50178, SELV, PELV.

- ▶ Disconnect power.
- ▶ Connect the unit as follows:

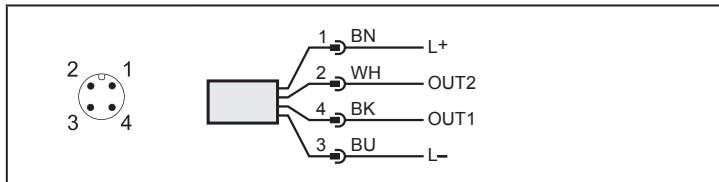

Colours to DIN EN 60947-5-2

BK: black; BN: brown; BU: blue; WH: white

Pin	Connection
4 (OUT1)	<ul style="list-style-type: none">• switching signal for volumetric flow• switching signal for temperature• switching signal for volumetric flow direction• switching signal for preset counter• pulse signal for quantity meter• frequency signal for volumetric flow• frequency signal for temperature• IO-Link• OFF
2 (OUT2/InD)	<ul style="list-style-type: none">• switching signal for volumetric flow• switching signal for temperature• switching signal for volumetric flow direction• analogue signal for volumetric flow• analogue signal for temperature• input for external meter reset signal (InD)• OFF

Circuit examples:

1 2 x PnP

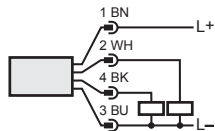

2 2 x nPn

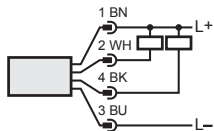

3 1 x PnP / 1 x analogue

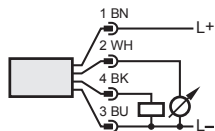

4 1 x nPn / 1 x analogue

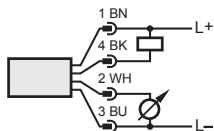

UK

8 Operating and display elements

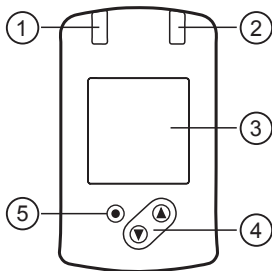

1 and 2: Switching status LEDs

- LED 1 = switching status OUT1 (on if output 1 is switched)
- LED 2 = switching status OUT2 (on if output 2 is switched)

3: TFT display

- Display of the current process values (volumetric flow, temperature, totaliser)
- Display of the parameters and parameter values

4: Buttons [▲] and [▼]

- Select parameter
- Change parameter value (hold button pressed)
- Change of the process value display in the normal operating mode (RUN mode)
- Locking / unlocking (buttons pressed simultaneously > 10 seconds)

5: Button [●] = Enter

- Change from the RUN mode to the main menu
- Change to the setting mode
- Apply the set parameter value



Display illumination:

- Device temperature > 70 °C: brightness automatically reduced.
- Device temperature ≥ 100 °C: display automatically switched off.

9 Menu

9.1 Process value display (RUN)

It is possible to select three process value indications during operation:

- ▶ Press button [▲] or [▼].
- > The display changes between the standard indication and two other views.
- > After 30 s, the device returns to the standard display.

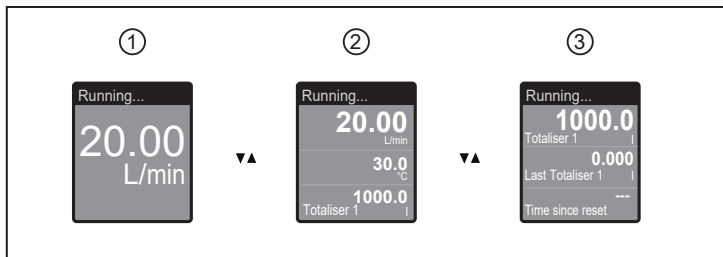

- 1: Standard display as set under [diS.L] (→ 11.5.2)
- 2: Overview of all process values
- 3: Overview totaliser values

9.2 Main menu

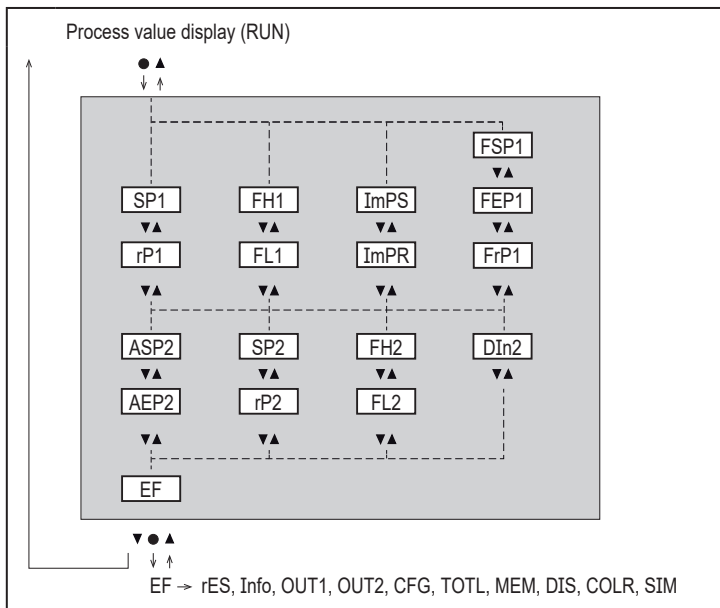

Explanation of the parameters → 9.4 Submenu OUT1 and OUT2

9.3 Extended functions EF

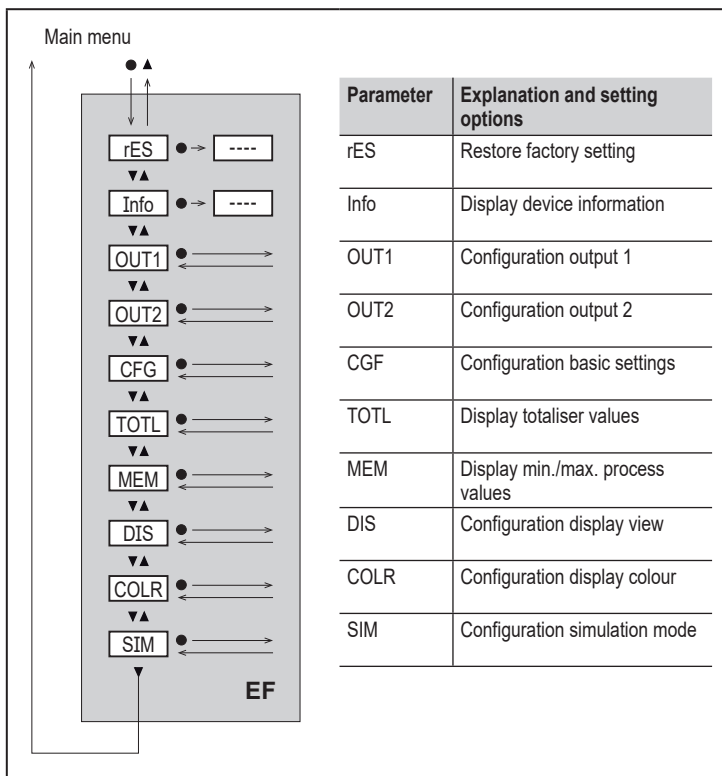

UK

9.4 Submenu OUT1 and OUT2

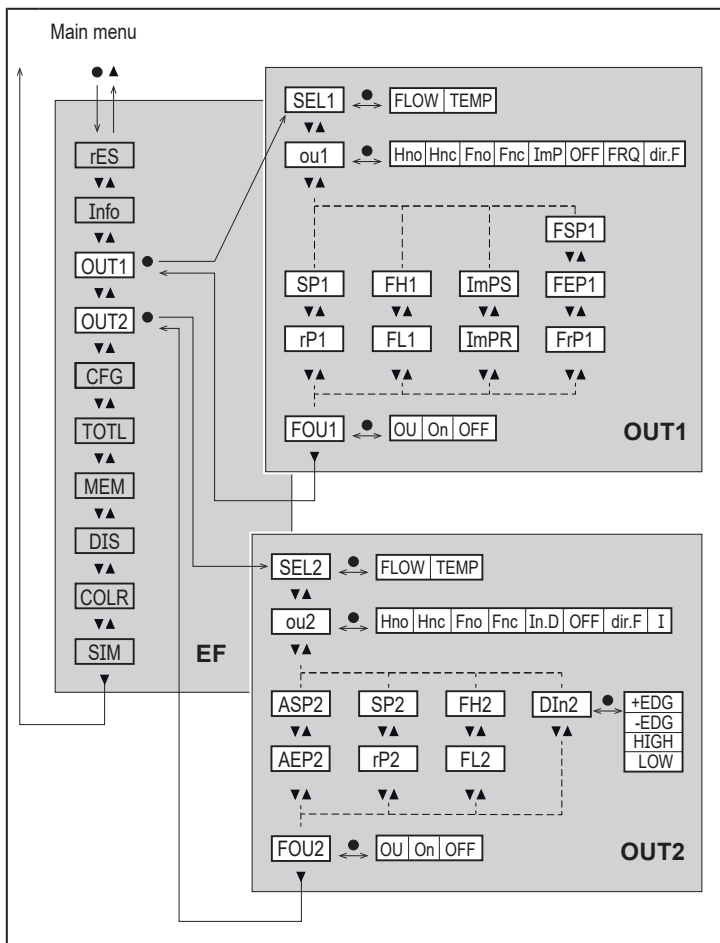

Explanation submenu OUT1

Parameter	Explanation and setting options
SEL1	Standard measured variable for evaluation by OUT1: FLOW (volumetric flow) or TEMP (temperature)
ou1	Output function for OUT1: <ul style="list-style-type: none"> • Volumetric flow: Hno, Hnc, Fno, Fnc, ImP, OFF, FRQ, dir.F • Temperature: Hno, Hnc, Fno, Fnc, OFF, FRQ <p>Hno = switching signal with hysteresis function normally open Hnc = switching signal with hysteresis function normally closed Fno = switching signal with window function normally open Fnc = switching signal with window function normally closed ImP = consumed quantity monitoring (totaliser function) OFF = output OFF (of high impedance) FRQ = frequency signal dir.F = detection of the volumetric flow direction</p>
SP1	Set point for OUT1
rP1	Reset point for OUT1
FH1	Upper limit for OUT1
FL1	Lower limit for OUT1
ImPS	Pulse value = volumetric flow quantity at which 1 pulse is delivered.
ImPR	Configuration of the output for consumed quantity monitoring: YES (pulse signal), no (switching signal).
FSP1	Start point for OUT1, only for SEL1 = TEMP (temperature)
FEP1	End point for OUT1
FrP1	Frequency for end point FEP1 at OUT1
FOU1	Status of OUT 1 in case of an internal fault: OU = output 1 switches irrespective of the fault as defined with the parameters. On = output switches ON / frequency signal goes to the upper final value. OFF = output switches OFF / frequency signal goes to 0.  FOU1 is not available if ou1 = ImP.

Explanation submenu OUT2

Parameter	Explanation and setting options
SEL2	Standard measured variable for evaluation by OUT2: FLOW (volumetric flow) or TEMP (temperature)
ou2	Output function for OUT2: <ul style="list-style-type: none"> • Volumetric flow: Hno, Hnc, Fno, Fnc, In.D, OFF, dir.F, I • Temperature: Hno, Hnc, Fno, Fnc, OFF, I <p>Hno = switching signal with hysteresis function normally open Hnc = switching signal with hysteresis function normally closed Fno = switching signal with window function normally open Fnc = switching signal with window function normally closed In.D = input for external meter reset signal OFF = output OFF (of high impedance) dir.F = detection of the volumetric flow direction I = analogue signal 4...20 mA.</p>
SP2	Set point for OUT2
rP2	Reset point for OUT2
FH2	Upper limit for OUT2
FL2	Lower limit for OUT2
ASP2	Analogue start point for OUT2
AEP2	Analogue end point for OUT2
DIn2	Reset of totaliser Vol.1 via external signal: +EDG, -EDG, HIGH, LOW
FOU2	Status of OUT 2 in case of an internal fault: OU = output switches irrespective of the fault as defined with the parameters. On = output switches ON / analogue signal goes to 21.5 mA. OFF = output switches OFF / analogue signal goes to 3.5 mA.

9.5 Submenu CFG and TOTL

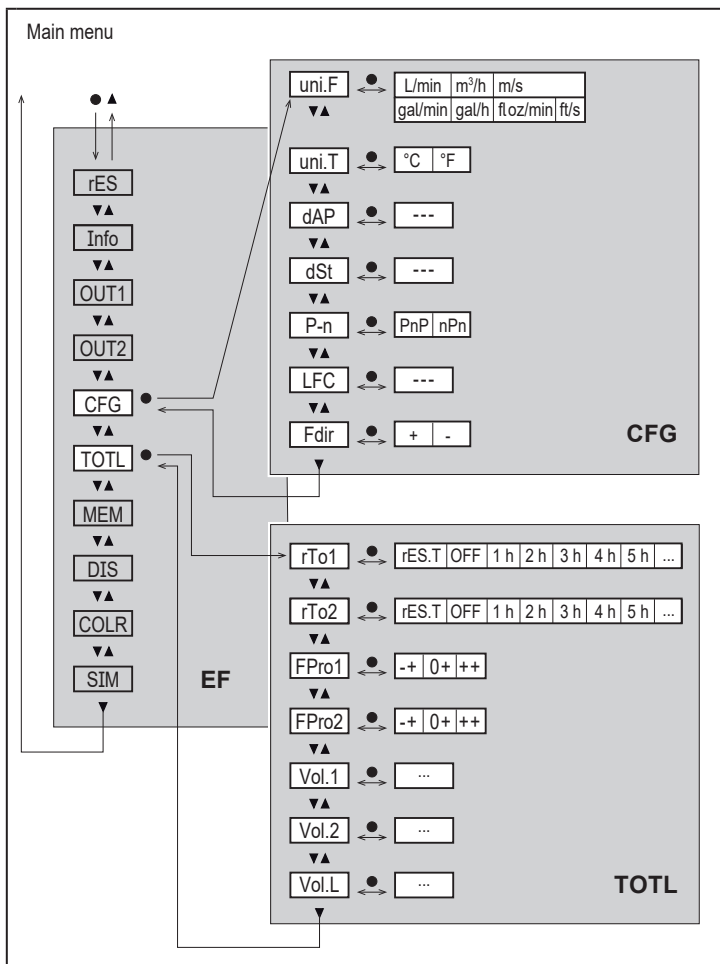

Explanation submenu CFG

Parameter	Explanation and setting options
uni.F	Standard unit of measurement for volumetric flow: m/s, l/min*, m ³ /h, gal/min, gal/h, floz/min, ft/s (*SM4: ml/min)
uni.T	Standard unit of measurement for temperature: °C or °F
dAP	Measured value damping for switching output in seconds (only volumetric flow)
dSt	Start-up delay in seconds (only volumetric flow)
P-n	Output logic: PnP or nPn
LFC	Low flow cut-off
Fdir	Volumetric flow direction: + or -

Explanation submenu TOTL

Parameter	Explanation and setting options
rTo1	Reset of totaliser Vol.1: OFF, res.T or time
rTo2	Reset of totaliser Vol.2: OFF, res.T or time
FPro1	Metering method of totaliser Vol.1: 0+ or - + or ++
FPro2	Metering method of totaliser Vol.2: 0+ or - + or ++
Vol.1	Display of current meter reading totaliser 1
Vol.2	Display of current meter reading totaliser 2
Vol.L	Display of current meter reading over the whole lifetime

9.6 Submenu MEM and DIS

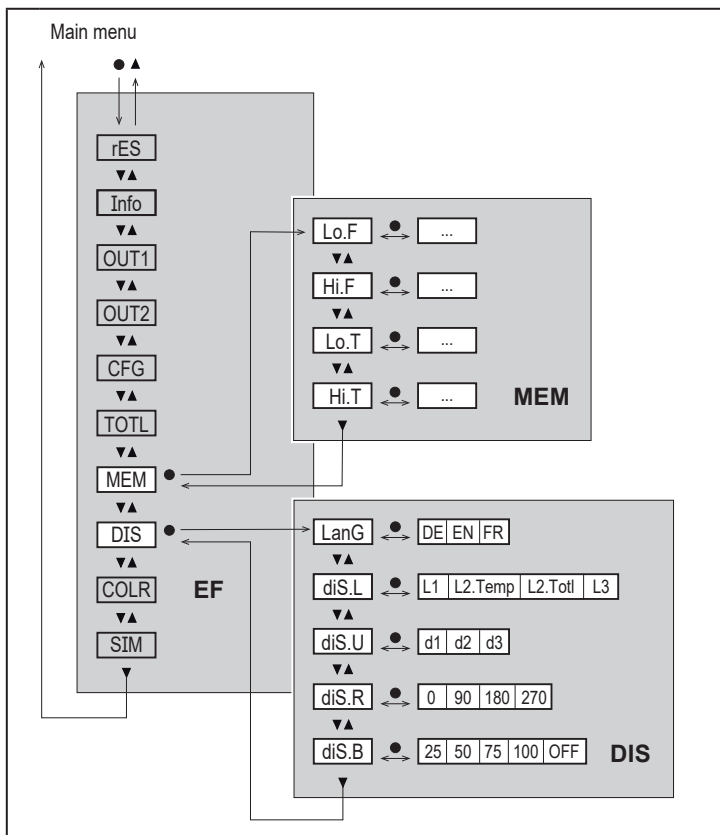

Explanation submenu MEM

Parameter	Explanation and setting options
Lo.F	Min. value of the volumetric flow quantity measured in the process
Hi.F	Max. value of the volumetric flow quantity measured in the process
Lo.T	Min. value of the temperature measured in the process
Hi.T	Max. value of the temperature measured in the process

Explanation submenu DIS

Parameter	Explanation and setting options
LanG	Menu language: DE or EN or FR
diS.L	Standard process value display (in selected standard unit of measurement) L1 = current process value for volumetric flow L2.Temp = current process value for volumetric flow and temperature L2.Totl = current process value for volumetric flow and totaliser Vol.1 L3 = current process value for volumetric flow and temperature and totaliser Vol.1
diS.U	Display refresh rate: d1 = high d2 = medium d3 = low
diS.R	Display rotation: 0°, 90°, 180°, 270°
diS.B	Display brightness: 25 %, 50 %, 75 %, 100 %, OFF (measured value display in the RUN mode switched off)

9.7 Submenu COLR and SIM

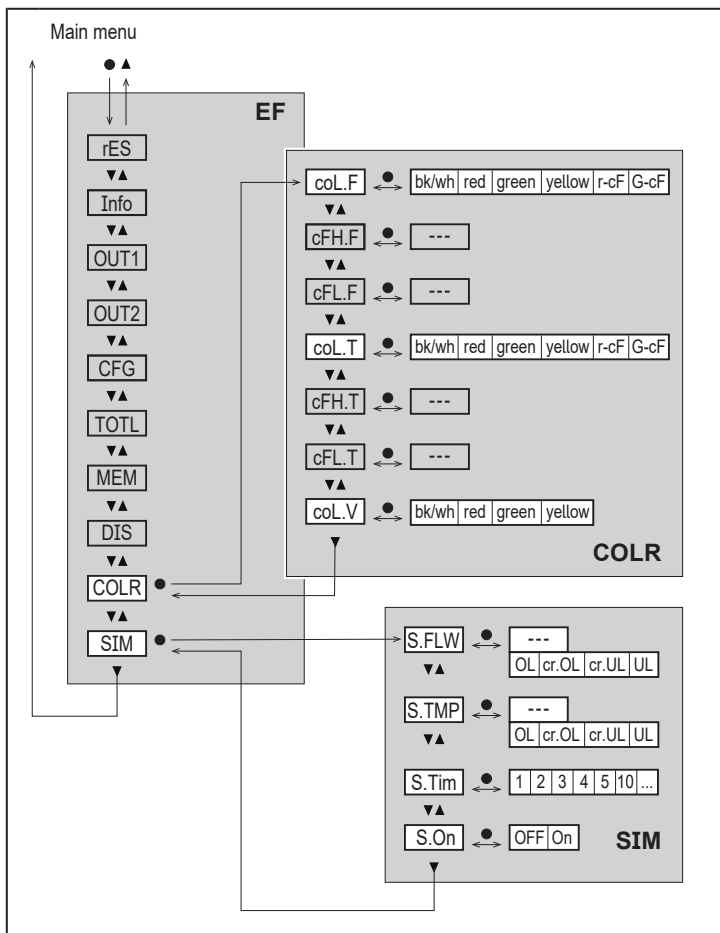

Explanation submenu COLR

Parameter	Explanation and setting options
coL.F	Colour of the characters in the display for the volumetric flow value
cFH.F	Upper limit of the colour change for volumetric flow measurement
cFL.F	Lower limit of the colour change for volumetric flow measurement
coL.T	Colour of the characters in the display for the temperature value
cFH.T	Upper limit of the colour change for temperature measurement
cFL.T	Lower limit of the colour change for temperature measurement
coL.V	Colour of the characters in the display for totaliser value Vol.1
bk/wh	Permanently black/white
yellow	Permanently yellow
green	Permanently green
red	Permanently red
r-cF	Display colour red between the limits cFL...cFH, outside colour change to green
G-cF	Display colour green between the limits cFL...cFH, outside colour change to red

Explanation submenu SIM

Parameter	Explanation and setting options
S.FLW	Simulated volumetric flow value
S.TMP	Simulated temperature value
cr.UL	Measured value below the detection zone → error message
UL	Measured value below the display range → warning
OL	Measured value above the display range → warning
cr.OL	Measured value above the detection zone → error message
S.Tim	Simulation time in minutes
S.On	Simulation status: OFF, On

10 Set-up

After power on and expiry of the power-on delay time of approx. 5 s the unit is in the Run mode (= normal operating mode). It carries out its measurement and evaluation functions and generates output signals according to the set parameters.

- During the power-on delay time the outputs are switched as programmed:
 - ON with normally open function (Hno / Fno)
 - OFF with normally closed function (Hnc / Fnc)
 - ON for detection of flow direction (dir.F)
 - OFF for frequency output (FRQ)
 - OFF for consumed quantity monitoring (ImP)
- If output 2 is configured as analogue output, the output signal is at 20 mA during the power-on delay time.

UK

11 Parameter setting



CAUTION

If the medium temperature is above 50 °C (122 °F) parts of the housing can increase in temperature to over 65 °C (149 °F).

> Risk of burns.

- ▶ Do not touch the device with your hands.
- ▶ Use another object (e.g. a ballpoint pen) to carry out settings on the unit.

Parameters can be set before installation or during operation.



If you change parameters during operation, this will influence the function of the plant.

- ▶ Ensure that there will be no malfunctions in your plant.

During parameter setting the unit remains in the operating mode. It continues to monitor with the existing parameter until the parameter setting has been completed.



The parameters can also be set via the IO-Link interface.

11.1 Parameter setting in general

1. Change from the RUN mode to the main menu	[●]
2. Select the requested parameter	[▲] or [▼]
3. Change to the setting mode	[●]
4. Modification of the parameter value	[▲] or [▼] > 1 s
5. Apply the set parameter value	[●]
6. Return to the RUN mode	> 30 seconds (timeout)



If [🔒 Locked via Communication] is displayed when you try to change a parameter value, an IO-Link communication is active (temporary locking).



If [🔒 Locked via system] is displayed, the sensor is permanently locked via software. This locking can only be removed with a parameter setting software.

11.1.1 Select submenu

1. Press [●] to change from the process value display to the main menu.
2. Press [▼] to select the menu EF and press [●].
3. Press [▼] to select the submenu and press [●].

11.1.2 Change to the process value display (RUN mode)

There are 2 possibilities:

1. Wait for 30 seconds (→ 11.1.4 Timeout).
2. Press [▲] or [▼] to go to the end of the menu and change to the next higher menu.

11.1.3 Locking / unlocking

The unit can be locked electronically to prevent unintentional settings. On delivery: not locked.

Locking:

- ▶ Make sure that the unit is in the normal operating mode.
- ▶ Press [▲] and [▼] simultaneously for 10 s until [🔒 Set menu lock] is displayed.



During operation: [🔒] is displayed if you try to change parameter values.

Unlocking:

- ▶ Make sure that the unit is in the normal operating mode.
- ▶ Press [▲] and [▼] simultaneously for 10 s until [Reset menu lock] is displayed.



Via the IO-Link interface the setting buttons can be locked with [Lock via system] so that you can no longer set parameters on the unit.

11.1.4 Timeout

If no button is pressed for 30 s during parameter setting, the unit returns to the operating mode with unchanged values.

UK

11.2 Settings for volumetric flow monitoring

11.2.1 Limit monitoring OUT1 or OUT2 / hysteresis function

<ul style="list-style-type: none">▶ Select [uni.F] and set the unit of measurement.▶ Select [SELx] and set FLOW.▶ Select [oux] and set the switching signal:<ul style="list-style-type: none">- Hno = hysteresis function / normally open- Hnc = hysteresis function / normally closed▶ Select [SPx] and set the value at which the output switches.▶ Select [rPx] and set the value at which the output switches off.	Menu OUTx: [SELx] [oux] [SPx] [rPx]
---	---

11.2.2 Limit monitoring OUT1 or OUT2 / window function

<ul style="list-style-type: none">▶ Select [uni.F] and set the unit of measurement.▶ Select [SELx] and set FLOW.▶ Select [oux] and set the switching signal:<ul style="list-style-type: none">- Fno = window function / normally open- Fnc = window function / normally closed▶ Select [FHx] and set the upper limit of the window section.▶ Select [FLx] and set the lower limit of the window section.	Menu OUTx: [SELx] [oux] [FHx] [FLx]
---	---

11.2.3 Switching signal volumetric flow direction OUT1 or OUT2

<ul style="list-style-type: none">▶ Select [SELx] and set FLOW.▶ Select [oux] and select detection of flow direction dir.F> Output switches when the volumetric flow direction is reversed (→ 5.2.2).	Menu OUTx: [SELx] [oux]
--	-------------------------------

11.2.4 Frequency signal volumetric flow OUT1

<ul style="list-style-type: none">▶ Select [uni.F] and set the unit of measurement.▶ Select [SEL1] and set FLOW.▶ Select [ou1] and select frequency signal: FRQ▶ Select [FEP1] and set the upper volumetric flow value at which the frequency set in FrP1 is provided.▶ Select [FrP1] and set the frequency.	Menu OUT1: [SEL1] [ou1] [FEP1] [FrP1]
--	---

11.2.5 Analogue signal volumetric flow OUT2

<ul style="list-style-type: none">▶ Select [uni.F] and set the unit of measurement.▶ Select [SEL2] and set FLOW.▶ Select [ou2] and select analogue signal: I (4...20 mA)▶ Select [ASP] and set the value at which 4 mA is provided.▶ Select [AEP] and set the value at which 20 mA is provided.	Menu OUT2: [SEL2] [ou2] [ASP2] [AEP2]
---	---

11.3 Settings for consumed quantity monitoring

11.3.1 Metering method of the totalisers

<ul style="list-style-type: none">▶ Select [FPro1] and set the metering method for totaliser Vol.1.▶ Select [FPro2] and set the metering method for totaliser Vol.2. <p>0+ = totalling only positive volumetric flow values -+ = totalling the volumetric flow quantity values with the correct sign ++ = all volumetric flow quantities are totalled irrespective of the volumetric flow direction</p>	Menu TOTL: [FPro1] [FPro2]
--	----------------------------------

11.3.2 Quantity monitoring via pulse output OUT1

<ul style="list-style-type: none">▶ Select [uni.F] and set the unit of measurement.▶ Select [SEL1] and set FLOW.▶ Select [ou1] and set pulse output: ImP▶ Select [ImPS] and set pulse value (= volumetric flow quantity at which a pulse is provided):<ol style="list-style-type: none">1. Press [▲] or [▼] to select the setting range.2. Briefly press [●] to confirm the setting range.3. Press [▲] or [▼] to set the requested numeric value.4. Briefly press [●] to apply the value.▶ Select [ImPR] and set YES.	Menu OUT1: [SEL1] [ou1] [ImPS] [ImPR]
--	---

11.3.3 Quantity monitoring via the preset counter OUT1

<ul style="list-style-type: none">▶ Select [uni.F] and set the unit of measurement.▶ Select [SEL1] and set FLOW.▶ Select [ou1] and set pulse output: ImP▶ Select [ImPS] and set the volumetric flow quantity at which output 1 switches.▶ Select [ImPR] and set no.	Menu OUT1: [SEL1] [ou1] [ImPS] [ImPR]
---	---

11.3.4 Manual meter reset

<ul style="list-style-type: none">▶ Select [rTo1] for totaliser Vol.1 or [rTo2] for totaliser Vol.2 and set rES.T.> The respective totaliser is reset to zero.	Menu TOTL: [rTo1] [rTo2]
--	--------------------------------

UK

11.3.5 Time-controlled meter reset

<ul style="list-style-type: none">▶ Select [rTo1] for totaliser Vol.1 or [rTo2] for totaliser Vol.2 and set the requested value (intervals of hours, days or weeks).> The respective totaliser is reset automatically with the value set.	Menu TOTL: [rTo1] [rTo2]
---	--------------------------------

11.3.6 Deactivate meter reset

<ul style="list-style-type: none">▶ Select [rTo1] for totaliser Vol.1 or [rTo2] for totaliser Vol.2 and set OFF.> The respective totaliser is only reset after overflow.	Menu TOTL: [rTo1] [rTo2]
--	--------------------------------

11.3.7 Meter reset via external signal

<ul style="list-style-type: none">▶ Select [ou2] and set In.D.▶ Select [DIn2] and set the meter reset signal:<ul style="list-style-type: none">- HIGH = reset for high signal- LOW = reset for low signal- +EDG = reset for rising edge- -EDG = reset for falling edge> Totaliser Vol.1 is reset to zero.	Menu OUT2: [ou2] [DIn2]
---	-------------------------------

 An external meter reset is only possible for totaliser Vol.1.

11.3.8 Read consumption values

<ul style="list-style-type: none">▶ Select [Vol.1], [Vol.2] or [Vol.L] to display the respective meter reading:<ul style="list-style-type: none">- [Vol.1] = current meter reading totaliser 1- [Vol.2] = current meter reading totaliser 2- [Vol.L] = current meter reading lifetime totaliser	Menu TOTL: [Vol.1] [Vol.2] [Vol.L]
---	---

11.4 Settings for temperature monitoring

11.4.1 Limit monitoring OUT1 or OUT2 / hysteresis function

<ul style="list-style-type: none">▶ Select [uni.T] and set the unit of measurement.▶ Select [SELx] and set TEMP.▶ Select [oux] and set the switching signal:<ul style="list-style-type: none">- Hno = hysteresis function / normally open- Hnc = hysteresis function / normally closed▶ Select [SPx] and set the value at which the output switches.▶ Select [rPx] and set the value at which the output switches off.	Menu OUTx: [SELx] [oux] [SPx] [rPx]
---	---

11.4.2 Limit monitoring OUT1 or OUT2 / window function

<ul style="list-style-type: none">▶ Select [uni.T] and set the unit of measurement.▶ Select [SELx] and set TEMP.▶ Select [oux] and set the switching signal:<ul style="list-style-type: none">- Fno = window function / normally open- Fnc = window function / normally closed▶ Select [FHx] and set the upper limit of the window section.▶ Select [FLx] and set the lower limit of the window section.	Menu OUTx: [SELx] [oux] [FHx] [FLx]
---	---

11.4.3 Frequency signal temperature OUT1

<ul style="list-style-type: none">▶ Select [uni.T] and set the unit of measurement.▶ Select [SEL1] and set TEMP.▶ Select [ou1] and select frequency function: FRQ▶ Select [FSP1] and set the lower temperature value from which a frequency signal is provided.▶ Select [FEP1] and set the upper temperature value at which the frequency set in FrP1 is provided.▶ Select [FrP1] and set the frequency.	Menu OUT1: [SEL1] [ou1] [FSP1] [FEP1] [FrP1]
---	---

11.4.4 Analogue signal temperature OUT2

<ul style="list-style-type: none">▶ Select [uni.T] and set the unit of measurement.▶ Select [SEL2] and set TEMP.▶ Select [ou2] and select analogue signal: I (4...20 mA)▶ Select [ASP] and set the value at which 4 mA is provided.▶ Select [AEP] and set the value at which 20 mA is provided.	Menu OUT2: [SEL2] [ou2] [ASP2] [AEP2]
---	---

11.5 User settings (optional)



11.5.1 Menu language

<ul style="list-style-type: none">▶ Select [LanG] and set menu language:<ul style="list-style-type: none">- DE = German- EN = English- FR = French	Menu DIS: [LanG]
--	---------------------

11.5.2 Standard display

<ul style="list-style-type: none">▶ Select [diS.L] and set process value display:<ul style="list-style-type: none">- L1 = current process value for volumetric flow- L2.Temp = current process value for volumetric flow and temperature- L2.Totl = current process value for volumetric flow and totaliser Vol.1- L3 = current process value for volumetric flow and temperature and totaliser Vol.1▶ Select [diS.U] and set the refresh rate of the display:<ul style="list-style-type: none">- d1 = high- d2 = medium- d3 = low▶ Select [diS.R] and set the orientation of the display: 0°, 90°, 180°, 270°▶ Select [diS.B] and set the brightness of the display: 25 %, 50 %, 75 %, 100 % or OFF (= energy-saving mode. The display is switched off in the operating mode. Error messages are displayed even if the display is deactivated. Display activation by pressing any button.)	Menu DIS: [diS.L] [diS.U] [diS.R] [diS.B]
---	---

11.5.3 Standard unit of measurement for volumetric flow

▶ Select [uni.F] and set the unit of measurement for standard display (→ 11.5.2).									Menu CFG: [uni.F]
	m/s	ml/min	l/min	m ³ /h	gal/min	gal/h	floz/min	ft/s	
SM4x	x	x		x	x	x	x	x	
SM6/SM7/SM8	x		x	x	x	x	x	x	
	Set [uni.F] prior to configuring the outputs.								
	The consumed quantity (meter reading) is automatically displayed in the unit of measurement providing the highest accuracy.								

11.5.4 Standard unit of measurement for temperature

▶ Select [uni.T] and set the unit of measurement for standard display (→ 11.5.2): °C or °F.	Menu CFG: [uni.T]
	Set [uni.T] prior to configuring the outputs.

11.5.5 Measured value damping

▶ Select [dAP] and set the damping constant in seconds (τ value 63 %).	Menu CFG: [dAP]
--	--------------------

11.5.6 Start-up delay

▶ Select [dSt] and set the switching delay in seconds.	Menu CFG: [dSt]
--	--------------------

11.5.7 Output logic

▶ Select [P-n] and set PnP or nPn.	Menu CFG: [P-n]
------------------------------------	--------------------

11.5.8 Low flow cut-off

▶ Select [LFC] and set the limit below which a volumetric flow is evaluated as standstill.	Menu CFG: [LFC]
--	--------------------

11.5.9 Volumetric flow direction

<ul style="list-style-type: none">▶ Select [Fdir] and set the volumetric flow direction:<ul style="list-style-type: none">+ = volumetric flow in direction of the arrow (= factory setting)- = volumetric flow against the direction of the arrow▶ Apply enclosed label over the arrow (→ 5.2.1)	Menu CFG: [Fdir]
--	---------------------

11.5.10 Colour of the characters in the display

<ul style="list-style-type: none">▶ Select [coL.F] for volumetric flow or [coL.T] for temperature and set the colour of the characters for the process value in the standard display:<ul style="list-style-type: none">- bk/wh = permanently black/white- yellow = permanently yellow- green = permanently green- red = permanently red- r-cF = display colour red between the limits cFL...cFH, outside colour change to green- G-cF = display colour green between the limits cFL...cFH, outside colour change to red▶ Select [cFH.x] and [cFL.x] and set the limits for the colour window:<ul style="list-style-type: none">- cFH.F = upper limit for volumetric flow- cFL.F = lower limit for volumetric flow- cFH.T = upper limit for temperature- cFL.T = lower limit for temperature▶ Select [coL.V] and set the colour of the characters for totaliser Vol.1:<ul style="list-style-type: none">- bk/wh = permanently black/white- yellow = permanently yellow- green = permanently green- red = permanently red	Menu COLR: [coL.F] [coL.T] [cFH.F] [cFL.F] [cFH.T] [cFL.T] [coL.V]
--	---

UK

11.5.11 Error behaviour of the outputs

<p>▶ Select [FOU1] and set the error behaviour for output 1:</p> <p>Switching output</p> <ul style="list-style-type: none">- On = Output 1 switches ON in case of an error- OFF = Output 1 switches OFF in case of an error- OU = Output 1 switches irrespective of the error as defined with the parameters <p>Frequency output</p> <ul style="list-style-type: none">- On = The frequency signal goes to the upper error value (→ 5.4)- OFF = The frequency signal goes to the lower error value (→ 5.4)- OU = The frequency signal corresponds to the measured value <p>▶ Select [FOU2] and set the error behaviour for output 2:</p> <p>Switching output</p> <ul style="list-style-type: none">- On = Output 2 switches ON in case of an error- OFF = Output 2 switches OFF in case of an error- OU = Output 2 switches irrespective of the error as defined with the parameters <p>Analogue output</p> <ul style="list-style-type: none">- On = The analogue signal goes to the upper error value (→ 5.5)- OFF = The analogue signal goes to the lower error value (→ 5.5)- OU = The analogue signal corresponds to the measured value <p> The parameter [FOUx] is not available if [ou1] = ImP (consumed quantity monitoring) is selected. Pulses or switching signals are provided irrespective of the error.</p>	<p>Menu OUT1: [FOU1]</p> <p>Menu OUT2: [FOU2]</p>
--	---

11.5.12 Restore factory setting

<p>▶ Select [rES].</p> <p>▶ Briefly press [●].</p> <p>▶ Keep [▲] or [▼] pressed.</p> <p>> [----] is displayed.</p> <p>▶ Briefly press [●].</p> <p>> The device carries out a reboot.</p> <p> → 15 Factory setting. We recommend taking down your own settings in that table before carrying out a reset.</p>	<p>Menu EF: [rES]</p>
--	---------------------------

11.6 Diagnostic functions

11.6.1 Read min/max values

<ul style="list-style-type: none">▶ Select [Lo.x] or [Hi.x] to display the highest or lowest process value measured:<ul style="list-style-type: none">- [Lo.F] = min. value of the volume flow measured in the process- [Hi.F] = max. value of the volume flow measured in the process- [Lo.T] = min. value of the temperature measured in the process- [Hi.T] = max. value of the temperature measured in the process <p>Delete memory:</p> <ul style="list-style-type: none">▶ Select [Lo.x] or [Hi.x].▶ Keep [▲] and [▼] pressed.> [----] is displayed.▶ Briefly press [●]. <p> It makes sense to delete the memories as soon as the unit operates under normal operating conditions for the first time.</p>	Menu MEM: [Lo.F] [Hi.F] [Lo.T] [Hi.T]
--	---

UK

11.6.2 Simulation

<ul style="list-style-type: none">▶ Select [S.FLW] and set the volume flow value to be simulated.▶ Select [S.TMP] and set the temperature value to be simulated.▶ Select [S.Tim] and set the time of the simulation in minutes.▶ Select [S.On] and set the function:<ul style="list-style-type: none">- On = The simulation starts. The values are simulated for the time set under [S.Tim]. Abort by pressing any button.- OFF = The simulation is not active.	Menu SIM: [S.FLW] [S.TMP] [S.Tim] [S.On]
---	--

12 Operation

The process values to be displayed permanently can be preset (→ 11.5.2 Standard display). A standard unit of measurement can be defined for the volumetric flow measurement and temperature measurement (→ 11.5.3 and → 11.5.4).

As an option for the preset standard display, the display can be changed by pressing the button [▲] or [▼] → 9.1 Process value display (RUN).

13 Troubleshooting

The unit has many self-diagnostic options. It monitors itself automatically during operation.

Warnings and error states are displayed even if the display is switched off. Error indications are also available via IO-Link.

The status signals are classified according to NAMUR recommendation NE107.











If several diagnostic events occur simultaneously, only the diagnostic message of the event with the highest priority is displayed.

If a process value fails, the other process values are still available.



Additional diagnostic functions are available via IO-Link → IODD interface description at www.ifm.com.

Process value line	Title line	Status LED	Type	Description	Output behaviour	Troubleshooting
ERROR	ERROR	--	⊗	Unit faulty / malfunction	FOU	Replace device.
Off	Off	--	⊗	Supply voltage too low	off	Check supply voltage. Change setting [diS.B] (→ 11.5.2)
---	---	---	⊗	Device temperature too high, display off	OU	Check device temperature.
---	---	---	⚠	Device temperature too high, display brightness reduced	OU	Check device temperature.
PARA	Parameter Error	---	⊗	Parameter setting outside the valid range	FOU	Repeat parameter setting.
ERROR	Flow Error	---	⊗	Error volumetric flow measurement	FOU	Check volumetric flow measurement. Replace device.
ERROR	Temp Error	---	⊗	Error in temperature measurement	FOU	Check temperature measurement. Replace device.

Process value line	Title line	Status LED	Type	Description	Output behaviour	Trouble-shooting
cr.OL	Critical over limit	---	⊗	Detection zone exceeded	FOU	Check volumetric flow range / temperature range.
cr.UL	Critical under limit	---	⊗	Detection zone not reached	FOU	Check volumetric flow range / temperature range.
---	Short circuit OUT1/OUT2	OUT1  OUT2 		Short circuit OUT1 and OUT2	---	Check switching outputs OUT1 and OUT2 for short circuit or excessive current
---	Short circuit OUT1	OUT1 		Short circuit OUT1	---	Check switching output OUT1 for short circuit or excessive current
---	Short circuit OUT2	OUT2 		Short circuit OUT2	---	Check switching output OUT2 for short circuit or excessive current
OL	Over limit	---		Measuring range exceeded	OU	Check volumetric flow range / temperature range.
UL	Under limit	---		Measuring range not reached	OU	Check volumetric flow range / temperature range.
Lock via key	---	---		Setting buttons on the unit locked, parameter change rejected	OU	Unlock unit (→ 11.1.3)
Lock via communication	---	---		Parameter setting locked via push-buttons, parameter setting is active via IO-Link communication	OU	Finish parameter setting via IO-Link communication.

UK

Process value line	Title line	Status LED	Type	Description	Output behaviour	Trouble-shooting
Lock via system	---	---		Setting buttons locked via parameter setting software, parameter change rejected	OU	Unlock the unit via IO-Link interface using the parameter setting software.
IO-Link	IO-Link flash	OUT1 OUT2		IO-Link function for optical identification of the unit active	OU	Deactivate IO-Link function.

Display range / detection zone → 5.5, figure 1.

Error In the event of an error, the outputs react according to the setting under [FOU1] and [FOU2] (→ 11.5.11).

Warning

LED flashes

LED flashes quickly

14 Maintenance, repair and disposal

As a rule, no measures for maintenance are necessary.

- ▶ Define regular calibration intervals according to the process requirements.
Recommendation: every 12 months.

If media with a tendency to build-up are used:

- ▶ Check measuring pipe at regular intervals and clean it, if necessary.

Only the manufacturer is allowed to repair the unit.

- ▶ After use dispose of the unit in an environmentally friendly way in accordance with the applicable national regulations.

15 Factory setting

Parameter	SM4020 SM4120	SM6020 SM6120 SM6420	SM6621	SM7020 SM7120 SM7420	SM7621	SM8020 SM8120 SM8420	SM8621	SM8030 SM8130
SEL1	FLOW	FLOW	FLOW	FLOW	FLOW	FLOW	FLOW	FLOW
ou1	Hno	Hno	Hno	Hno	Hno	Hno	Hno	Hno
SP1 / FH1	600 ml/min	5.00 l/min	1.32 gal/min	10.0 l/min	2.64 gal/min	20 l/min	5.28 gal/min	33.3 l/min
rP1 / FL1	548 ml/min	4.64 l/min	1.22 gal/min	9.2 l/min	2.44 gal/min	18.4 l/min	4.87 gal/min	30.7 l/min
FSP1	-20°C	-20°C	-4 °F	-20°C	-4 °F	-20°C	-4 °F	-20°C
FEP1	3000 ml/min 80°C	25 l/min 80°C	6.6 gal/min 176°F	50 l/min 80°C	13.21 gal/min 176°F	100 l/min 80°C	26.42 gal/min 176°F	166.7 l/min 80°C
FrP1	1000 Hz	1000 Hz	1000 Hz	1000 Hz	1000 Hz	1000 Hz	1000 Hz	1000 Hz
ImPS	0.001	0.001	0.0002	0.01	0.002	0.01	0.002	0.01
ImPR	Yes	Yes	Yes	Yes	Yes	Yes	Yes	Yes
FOU1	OFF	OFF	OFF	OFF	OFF	OFF	OFF	OFF
SEL2	FLOW	FLOW	FLOW	FLOW	FLOW	FLOW	FLOW	FLOW
ou2	I	I	I	I	I	I	I	I
ASP2	0	0	0	0	0	0	0	0
AEP2	3000 ml/min	25 l/min	6.6 gal/min	50 l/min	13.21 gal/min	100 l/min	26.42 gal/min	250 l/min
SP2 / FH2	1200 ml/min	10 l/min	2.64 gal/min	20 l/min	5.28 gal/min	40 l/min	10.57 gal/min	66.7 l/min
rP2 / FL2	1148 ml/min	9.63 l/min	2.54 gal/min	19.2 l/min	5.07 gal/min	38.4 l/min	10.15 gal/min	64 l/min
DIn2	+EDG	+EDG	+EDG	+EDG	+EDG	+EDG	+EDG	+EDG
FOU2	OFF	OFF	OFF	OFF	OFF	OFF	OFF	OFF
uni.F	ml/min	l/min	gal/min	l/min	gal/min	l/min	gal/min	l/min
uni.T	°C	°C	°F	°C	°F	°C	°C	°C
dAP	0.6	0.6	0.6	0.6	0.6	0.6	0.6	0.6
dST	0.0	0.0	0.0	0.0	0.0	0.0	0.0	0.0
P-n	PnP	PnP	PnP	PnP	PnP	PnP	PnP	PnP

UK

Parameter	SM4020 SM4120	SM6020 SM6120 SM6420	SM6621	SM7020 SM7120 SM7420	SM7621	SM8020 SM8120 SM8420	SM8621	SM8030 SM8130
LFC	5 ml	0.05 l/min	0.01 gal/min	0.01 l/min	0.03 gal/min	0.2 l/min	0.05 gal/min	0.2 l/min
Fdir	+	+	+	+	+	+	+	+
rTo1	OFF	OFF	OFF	OFF	OFF	OFF	OFF	OFF
rTo2	OFF	OFF	OFF	OFF	OFF	OFF	OFF	OFF
FPro1	0+	0+	0+	0+	0+	0+	0+	0+
FPro2	0+	0+	0+	0+	0+	0+	0+	0+
LanG	EN	EN	EN	EN	EN	EN	EN	EN
diS.L	L3	L3	L3	L3	L3	L3	L3	L3
diS.U	d3	d3	d3	d3	d3	d3	d3	d3
diS.B	75%	75%	75%	75%	75%	75%	75%	75%
col.F	bk/wh	bk/wh	bk/wh	bk/wh	bk/wh	bk/wh	bk/wh	bk/wh
col.T	bk/wh	bk/wh	bk/wh	bk/wh	bk/wh	bk/wh	bk/wh	bk/wh
col.V	bk/wh	bk/wh	bk/wh	bk/wh	bk/wh	bk/wh	bk/wh	bk/wh